

Outgassing Compliant Power Inductors AE613PMM



- Designed for use in multi-phase VRM/VRD regulators and high current/high frequency DC/DC converters.
- Passes NASA low outgassing specifications
- Tin-lead (Sn-Pb) terminations for the best possible board adhesion

Core material Ferrite

Terminations Tin-lead (63/37) over tin over nickel over copper.

Weight 5.0 – 5.4 g

Ambient temperature –55°C to +125°C with Irms current

Maximum part temperature +155°C (ambient + temp rise)

Storage temperature Component: –55°C to +155°C.

Tape and reel packaging: –40°C to +80°C

Resistance to soldering heat Max three 40 second reflows at +260°C, parts cooled to room temperature between cycles

Moisture Sensitivity Level (MSL) 1 (unlimited floor life at <30°C / 85% relative humidity)

Packaging 500/13" reel; Plastic tape: 24 mm wide, 0.4 mm thick, 16 mm pocket spacing, 8.1 mm pocket depth

PCB washing Tested to MIL-STD-202 Method 215 plus an additional aqueous wash. See [Doc787_PCB_Washing.pdf](#).

Part number ^{1,7}	L ² (μH)	DCR (mOhms) ³		SRF typ ⁴ (MHz)	Isat ⁵ (A)	Irms ⁶ (A)
		typ	max			
AE613PMM111MSZ	0.11	0.180	0.211	130	128	56
AE613PMM131MSZ	0.13	0.180	0.211	110	110	56
AE613PMM151MSZ	0.15	0.180	0.211	108	95	56
AE613PMM171MSZ	0.17	0.180	0.211	75	87	56
AE613PMM201MSZ	0.20	0.180	0.211	68	72	56
AE613PMM231MSZ	0.23	0.180	0.211	59	64	56
AE613PMM261MSZ	0.26	0.180	0.211	50	57	56
AE613PMM301MSZ	0.30	0.180	0.211	46	49	56
AE613PMM321MSZ	0.32	0.180	0.211	42	44	56
AE613PMM441MSZ	0.44	0.180	0.211	35	32	56

1. When ordering, please specify **tolerance** and **screening** codes:

AE613PMM441MSZ

Tolerance: M = 20%

Screening: Z = Unscreened

Y = Unscreened (SLDC Option A)

W = Unscreened (SLDC Option B)

H = Coilcraft CP-SA-10001 Group A

G = Coilcraft CP-SA-10001 Group A (SLDC Option A)

D = Coilcraft CP-SA-10001 Group A (SLDC Option B)

1 = EEE-INST-002 (Family 1) Level 1

2 = EEE-INST-002 (Family 1) Level 2

3 = EEE-INST-002 (Family 1) Level 3

4 = MIL-STD-981 (Family 04) Class B

5 = MIL-STD-981 (Family 04) Class S

F = ESCC3201 (F4 operational life performed at 105°C)

• Screening performed to the document's latest revision.

• Lot qualification (Group B) available.

• Testing T and U have been replaced with more detailed codes 4, 5, and 1, 2, 3, respectively. Codes T and U can still be used, if necessary. Custom testing also available.

2. Inductance tested at 100 kHz, 0.1 Vrms using an Agilent/HP 4263B LCR meter or equivalent.

3. DCR is measured on a micro-ohmmeter at points indicated in the dimensional diagram.

4. SRF measured with coils connected in series using an Agilent/HP 8753ES network analyzer or equivalent.

5. DC current at 25°C that causes an inductance drop of 20% (typ) from its value without current.

6. Current that causes the specified temperature rise from 25°C ambient. This information is for reference only and does not represent absolute maximum ratings.

7. Due to the design of this component, DWV and IR shall not be specified or tested.

8. Electrical specifications at 25°C.

Refer to Doc 362 "Soldering Surface Mount Components" before soldering.

Outgassing Compliant Power Inductors – AE613PMM Series

L vs Current

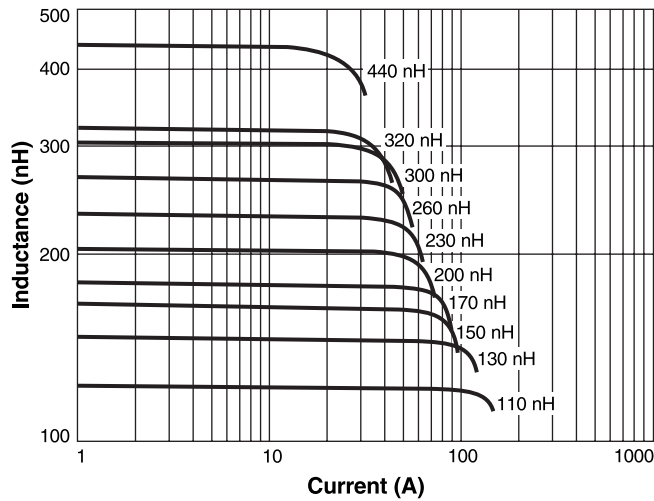

L vs Frequency

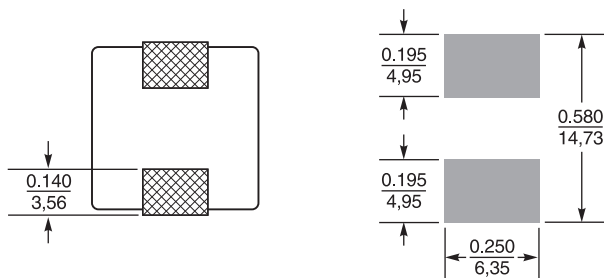
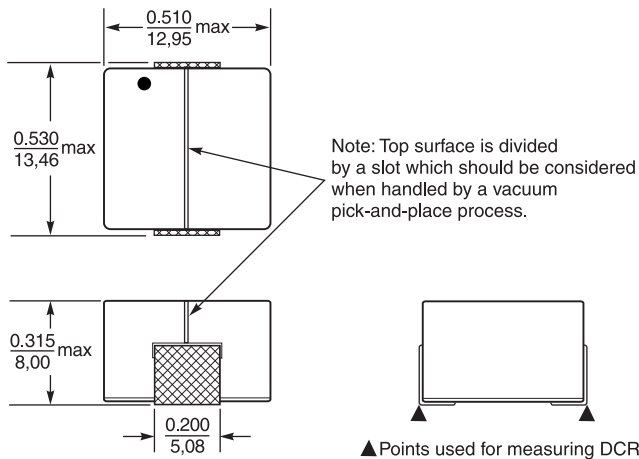
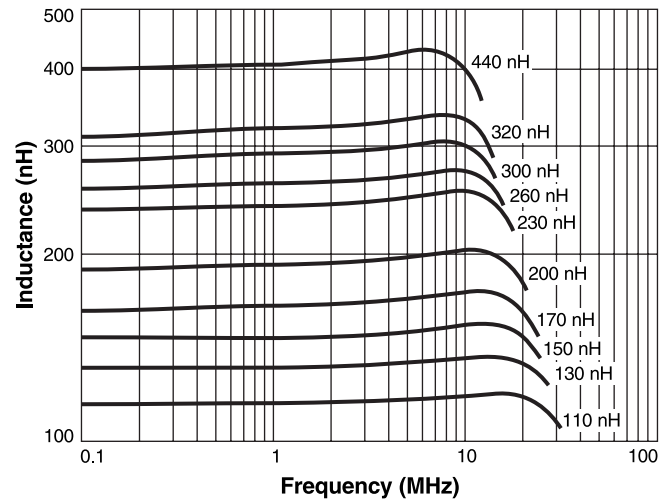

Dimensions are in $\frac{\text{inches}}{\text{mm}}$

Suggested Land Pattern



CRITICAL PRODUCTS & SERVICES
© Coilcraft, Inc. 2023

1102 Silver Lake Road
Cary, IL 60013
Phone 800-981-0363

Fax 847-639-1508
Email cps@coilcraft.com
www.coilcraft-cps.com

Document AE482-2 Revised 04/12/23

This product may not be used in medical or high risk applications without prior Coilcraft approval. Specifications subject to change without notice. Please check our web site for latest information.