

NEW!

Outgassing Compliant USB Chokes AR336FRB

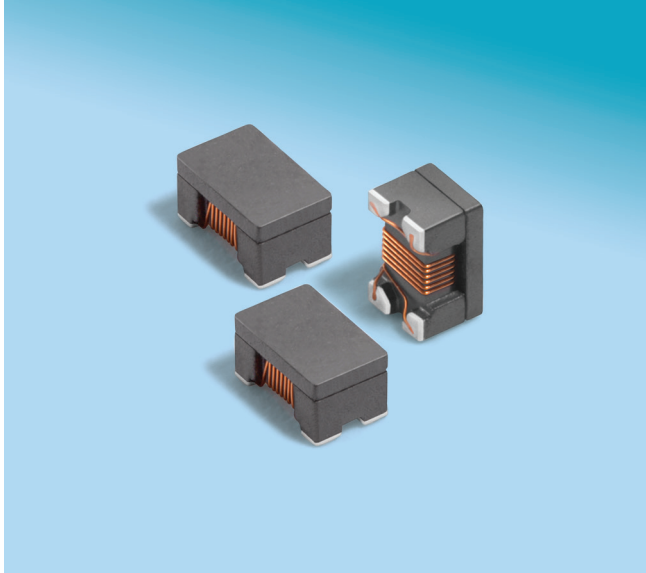

- For noise suppression in super high speed signal lines: USB 3.x, HDMI 2.0, HDBaseT™, DisplayPort, DVI, etc.; and in high speed differential signal lines: USB 2.0, IEEE1394, LVDS, etc.
- Suitable for USB-type C specification 1.0
- Up to 6 GHz differential mode 3 dB cutoff frequency; up to 30 dB common mode noise attenuation in GHz range
- Passes NASA low outgassing specifications

Core material Ferrite

Terminations Tin-lead (63/37) over tin over nickel over silver-palladium-glass frit

Weight 14.6 – 15.6 mg

Ambient temperature –40°C to +125°C with Irms current.

Maximum part temperature 140°C

Storage temperature Component: –55°C to +140°C.
Tape and reel packaging: –55°C to +80°C

Resistance to soldering heat Max three 40 second reflows at +260°C, parts cooled to room temperature between cycles

Moisture Sensitivity Level (MSL) 1 (unlimited floor life at <30°C / 85% relative humidity)

PCB washing Tested to MIL-STD-202 Method 215 plus an additional aqueous wash. See [Doc787_PCB_Washing.pdf](#).

Part number ¹	Common mode peak impedance (kOhms)	Cutoff frequency ² (GHz)	Common mode attenuation typ (dB)			Inductance ³ min (nH)	DCR max ⁴ (Ohms)	Isolation ⁵ (Vrms)	Imax (mA)
			10 MHz	100 MHz	500 MHz				
AR336FRB421MPZ	>0.14 @ >3.0GHz	6.6	0.50	4.6	6.9	28	0.110	250	500
AR336FRB901MPZ	>0.30 @ >3.0GHz	5.8	2.1	9.1	11.8	60	0.140	250	430
AR336FRB172MPZ	0.52 @ 2.5GHz	3.3	4.0	12.8	15.7	101	0.220	250	340
AR336FRB262MPZ	0.69 @ 2.0GHz	2.4	5.7	15.4	18.5	165	0.235	250	330
AR336FRB372MPZ	0.93 @ 1.8GHz	1.40	5.8	18.1	22.3	241	0.270	250	310
AR336FRB502MPZ	1.22 @ 1.5GHz	0.93	11.2	21.6	25.2	315	0.320	250	280
AR336FRB672MPZ	1.65 @ 1.2GHz	0.69	11.3	23.3	27.7	434	0.370	250	260
AR336FRB902MPZ	1.91 @ 1.0GHz	0.73	12.6	25.4	30.0	560	0.630	250	200

1. When ordering, please specify **termination** and **screening** codes:

AR336FRB902MPZ

Termination: P = Tin-lead (63/37) over tin over nickel over silver-palladium-glass frit.

R = Tin over nickel over silver-palladium-glass frit.
Not suitable for applications or screening with pure tin restrictions.

Screening: Z = Unscreened

H = Coilcraft CP-SA-10001 Group A

G = Coilcraft CP-SA-10001 Group A (SLDC Option A)

D = Coilcraft CP-SA-10001 Group A (SLDC Option B)

F = ESCC3201 (F4 operational life performed at 90°C)

1/2/3 = EEE-INST-002 (Family 1) Level 1/2/3

4/5 = MIL-STD-981 (Family 11) Class B=4, Class S=5

- Screening performed to the document's latest revision.
- Lot qualification (Group B) available.

2. Frequency at which the differential mode attenuation equals 3 dB.

3. Inductance measured at 100 MHz using an Agilent/HP 4286A impedance analyzer and a Coilcraft SMD-A fixture.

4. DCR is specified per winding.

5. Winding to winding isolation (hipot) tested for one minute.

6. Electrical specifications at 25°C.

Refer to Doc 362 "Soldering Surface Mount Components" before soldering.

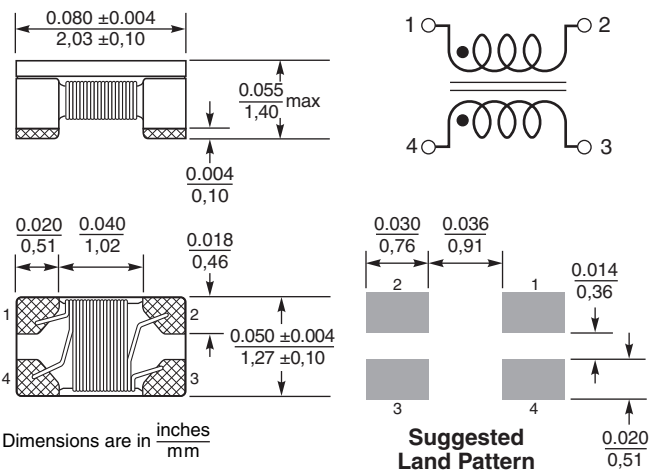

Note: Dimensions are before solder application. For maximum overall dimensions including solder, add 0.003 in / 0.076 mm to the maximum length, width and height.

Coilcraft CPS
CRITICAL PRODUCTS & SERVICES

1102 Silver Lake Road
Cary, IL 60013
Phone 800-981-0363

Fax 847-639-1508
Email cps@coilcraft.com
www.coilcraft-cps.com

Document AR1270-1 Revised 10/21/25

This product may not be used in medical or high risk applications without prior Coilcraft approval. Specifications subject to change without notice. Please check our web site for latest information.

USB 2.0 Common Mode Filter – AR336FRB

Typical Attenuation (Ref: 50 Ohms)

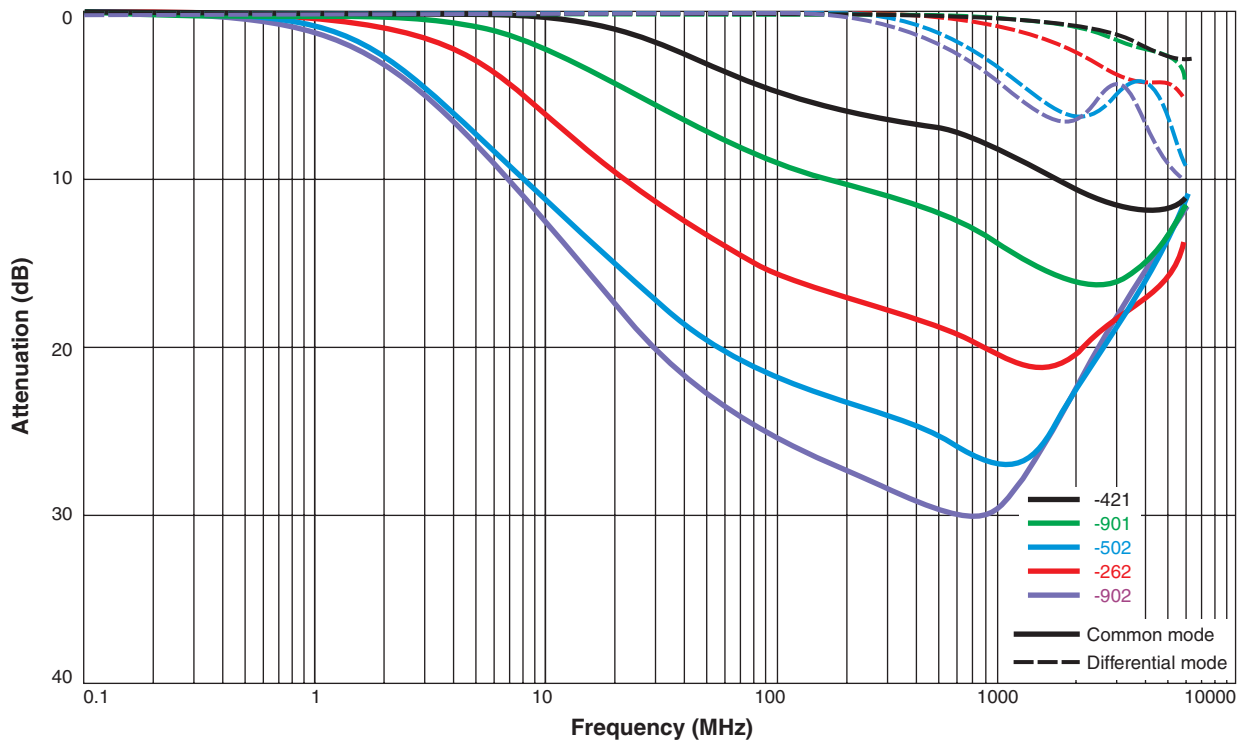

Typical Impedance vs Frequency

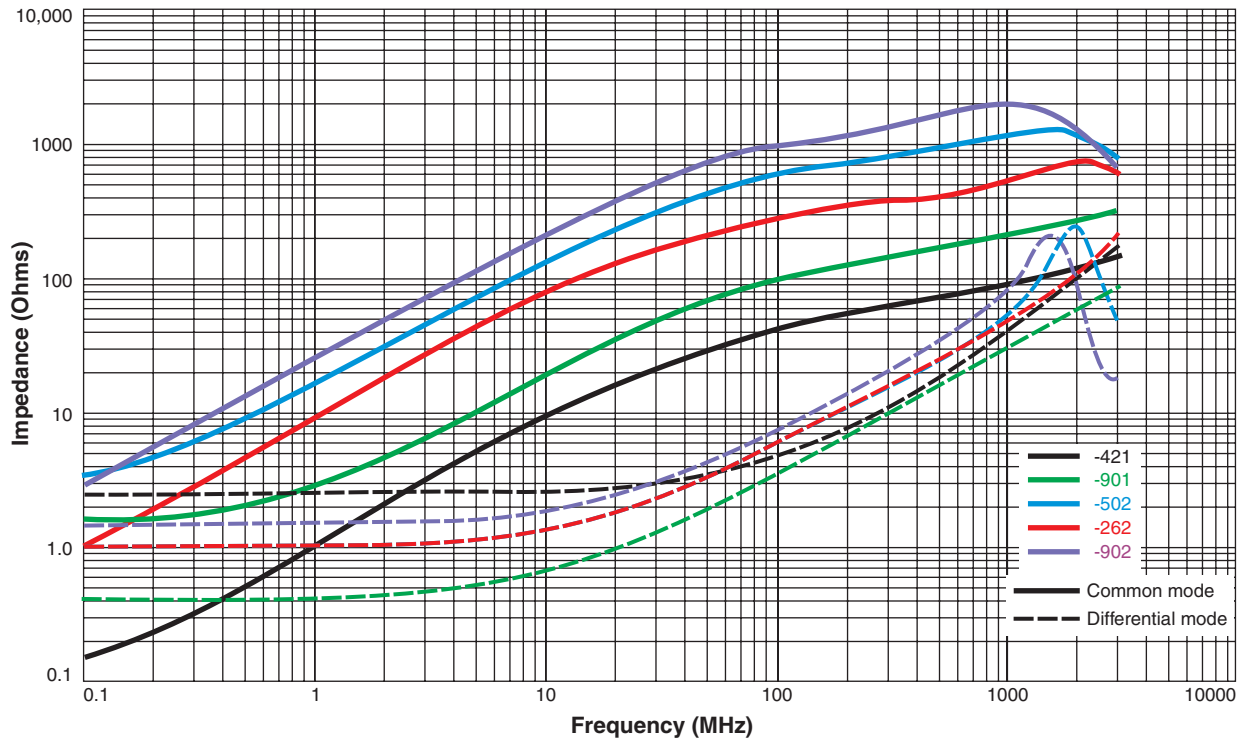

CRITICAL PRODUCTS & SERVICES

© Coilcraft, Inc. 2025

1102 Silver Lake Road
Cary, IL 60013
Phone 800-981-0363

Fax 847-639-1508
Email cps@coilcraft.com
www.coilcraft-cps.com

Document AR1270-2 Revised 10/21/25

This product may not be used in medical or high risk applications without prior Coilcraft approval. Specifications subject to change without notice. Please check our web site for latest information.