

Power Inductors for Critical Applications ST563PKP



- High energy storage and very low resistance
- High inductance values are perfect for EL driver applications.

Core material Ferrite

Core and winding loss See www.coilcraft.com/coreloss

Terminations Gold over nickel over phos bronze. Other terminations available at additional cost.

Weight 0.92– 1.23 g

Ambient temperature –40°C to +85°C with I_{rms} current, +85°C to +125°C with derated current

Storage temperature Component: –55°C to +125°C.
Tape and reel packaging: –55°C to +80°C

Resistance to soldering heat Max three 40 second reflows at +260°C, parts cooled to room temperature between cycles

Moisture Sensitivity Level (MSL) 1 (unlimited floor life at <30°C / 85% relative humidity)

Packaging 1000 per 13" reel Plastic tape: 24 mm wide, 0.33 mm thick, 12 mm pocket spacing, 5.8 mm pocket depth

Part number ¹	L ² (μ H)	Percent tol ³	DCR max (Ohms)	SRF typ ⁴ (MHz)	Isat ⁵ (A)	Irms ⁶ (A)
ST563PKP102MLZ	1.0	20	0.009	100	9.0	6.8
ST563PKP152MLZ	1.5	20	0.010	90	8.0	6.4
ST563PKP222_LZ	2.2	20,10	0.012	80	7.0	6.1
ST563PKP332_LZ	3.3	20,10	0.015	65	6.4	5.4
ST563PKP472_LZ	4.7	20,10	0.018	45	5.4	4.8
ST563PKP682_LZ	6.8	20,10	0.026	38	4.6	4.4
ST563PKP103_LZ	10	20,10	0.038	30	3.8	3.9
ST563PKP153_LZ	15	20,10	0.046	27	3.0	3.1
ST563PKP223_LZ	22	20,10	0.085	19	2.3	2.7
ST563PKP333_LZ	33	20,10	0.10	15	2.0	2.1
ST563PKP473_LZ	47	20,10	0.14	12	1.6	1.8
ST563PKP683_LZ	68	20,10	0.20	10	1.4	1.5
ST563PKP104_LZ	100	20,10	0.28	9	1.2	1.3
ST563PKP154_LZ	150	20,10	0.40	6	1.0	1.0
ST563PKP224_LZ	220	20,10	0.61	5	0.80	0.80
ST563PKP334_LZ	330	20,10	1.02	4.5	0.60	0.60
ST563PKP474_LZ	470	20,10	1.27	3.5	0.50	0.50
ST563PKP684_LZ	680	20,10	2.02	2.5	0.40	0.40
ST563PKP105_LZ	1000	20,10	3.00	2.0	0.30	0.30
ST563PKP155_LZ	1500	20,10	4.49	1.7	0.29	0.27
ST563PKP335_LZ	3300	20,10	8.97	1.1	0.19	0.17

1. When ordering, specify **tolerance, termination** and **screening** codes:

ST563PKP105MLZ

Tolerance: M = 20%, K = 10%

Termination: L = Gold over nickel over phos bronze.
Special order: T = Tin-silver-copper (95.5/4/0.5) or
S = Tin-lead (63/37).

Screening: Z = Unscreened

H = Group A screening per Coilcraft CP-SA-10001

G = Coilcraft CP-SA-10001 Group A (SLDC Option A)

D = Coilcraft CP-SA-10001 Group A (SLDC Option B)

All screening performed to the document's latest revision

2. Tested at 100 kHz, 0.1 Vrms, 0 Adc using an Agilent/HP 4263B LCR meter or equivalent.
3. Tolerances in bold are stocked for immediate shipment.
4. SRF >13 MHz measured using Agilent/HP 8753D network analyzer; <13 MHz using Agilent/HP 4192A.
5. DC current at 25°C that causes a 10% (typ) inductance drop from its value without current.
6. Current that causes a 40°C temperature rise from 25°C ambient. This information is for reference only and does not represent absolute maximum ratings.
7. Electrical specifications at 25°C.

Refer to Doc 362 "Soldering Surface Mount Components" before soldering.

Power Inductors for Critical Applications ST563PKP

Typical L vs Frequency

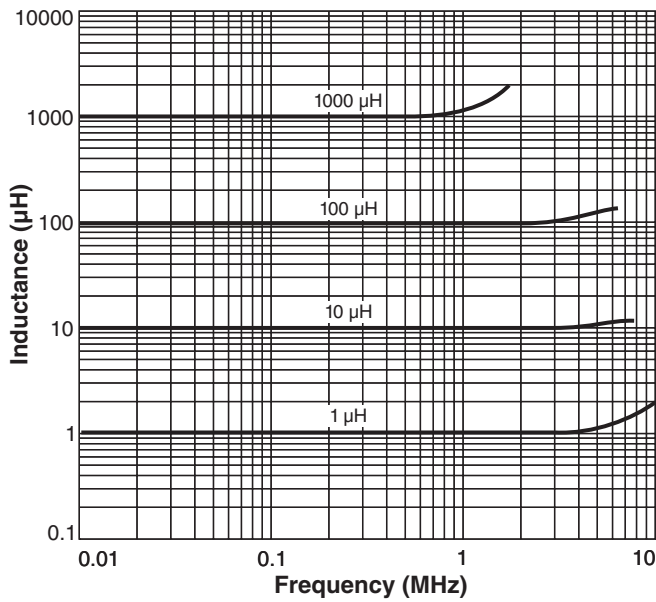

Typical L vs Current

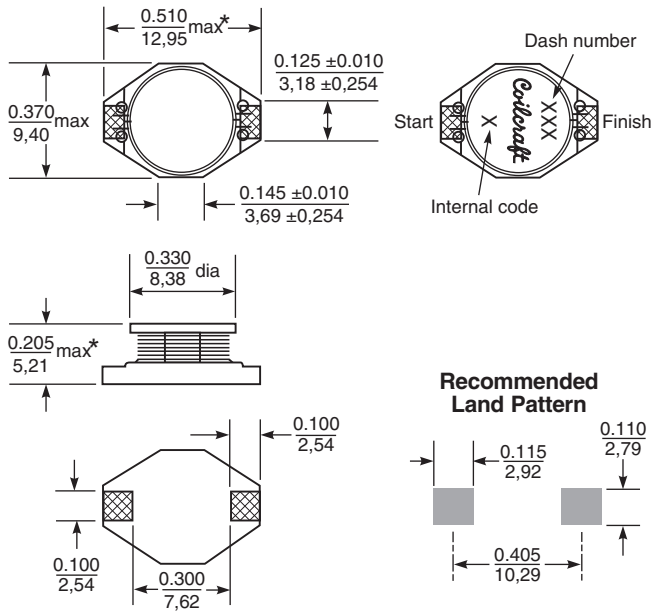
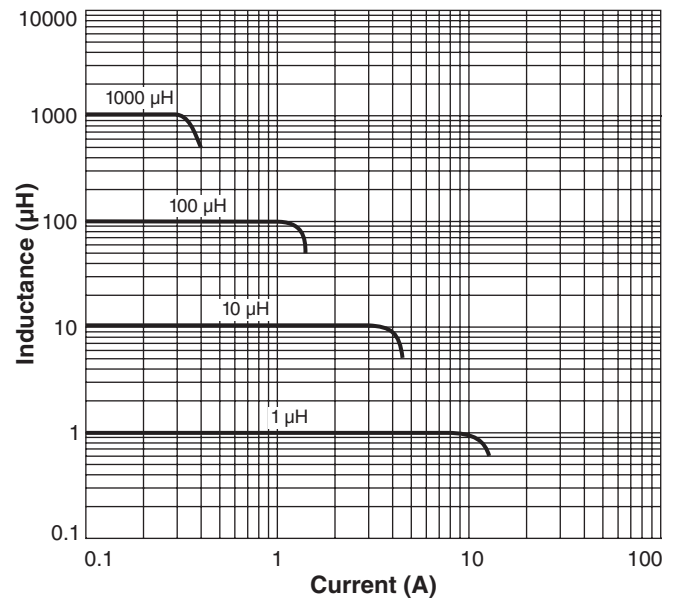

* Allow an additional 0.01/0.254 in length and 0.005/0.127 in height for optional tin-lead and tin-silver-copper application.

Dimensions are in inches/mm

