

High-Reliability Power Inductors MS420PJB



- High temperature materials allow operation in ambient temperatures up to 155°C.
- Special construction allows it to pass vibration testing to 80 G and shock testing to 1000 G.
- Tin-lead (Sn-Pb) termination for the best possible board adhesion

Core material Ferrite

Terminations Tin-lead (63/37) over tin over nickel.

Weight 70 – 85 mg

Ambient temperature –55°C to +105°C with Irms current

Maximum part temperature +155°C (ambient + temp rise)

Storage temperature Component: –55°C to +155°C.

Packaging: –55°C to +80°C

Resistance to soldering heat Max three 40 second reflows at +260°C, parts cooled to room temperature between cycles

Moisture Sensitivity Level (MSL) 1 (unlimited floor life at <30°C / 85% relative humidity)

Enhanced crush-resistant packaging 1000/7" reel;

Plastic tape: 12 mm wide, 0.3 mm thick, 8 mm pocket spacing, 1.02 mm pocket depth

Recommended pick and place nozzle OD: 5 mm; ID: ≤ 2.5 mm

Typical L vs Current

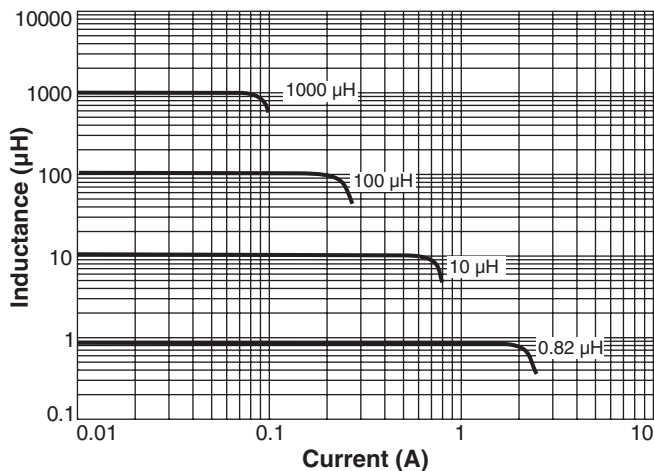

Typical L vs Frequency

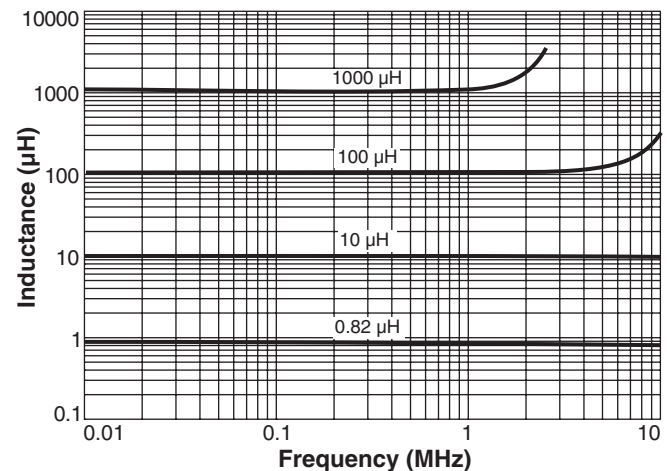

MS420PJB Series (5010)

Part number ¹	Inductance ² ±20% (µH)	DCR max ³ (Ohms)	SRF (MHz) ⁴		Isat (A) ⁵			Irms (A) ⁶	
			min	typ	10% drop	20% drop	30% drop	20°C rise	40°C rise
MS420PJB471MSZ	0.47	0.038	203	290	3.1	3.3	3.4	1.6	2.2
MS420PJB821MSZ	0.82	0.058	136.5	195	2.3	2.5	2.6	1.0	1.2
MS420PJB152MSZ	1.5	0.072	117.6	168	1.7	1.8	1.9	0.72	1.1
MS420PJB222MSZ	2.2	0.100	100.8	144	1.4	1.5	1.6	0.70	1.0
MS420PJB332MSZ	3.3	0.125	73.5	105	1.1	1.2	1.3	0.69	0.88
MS420PJB472MSZ	4.7	0.175	53.2	76	0.95	1.1	1.1	0.68	0.78
MS420PJB562MSZ	5.6	0.240	52.5	75	0.90	0.97	1.00	0.60	0.74
MS420PJB682MSZ	6.8	0.255	49.7	71	0.82	0.90	0.93	0.59	0.68
MS420PJB103MSZ	10	0.350	35.7	51	0.66	0.72	0.74	0.58	0.64
MS420PJB153MSZ	15	0.500	27.3	39	0.55	0.59	0.62	0.54	0.60
MS420PJB223MSZ	22	0.670	22.4	32	0.47	0.51	0.53	0.37	0.50
MS420PJB333MSZ	33	1.05	18.2	26	0.38	0.42	0.43	0.32	0.44
MS420PJB473MSZ	47	1.45	14.0	20	0.31	0.34	0.36	0.26	0.35
MS420PJB683MSZ	68	2.00	10.5	15	0.26	0.29	0.30	0.20	0.28
MS420PJB104MSZ	100	3.10	8.40	12	0.21	0.23	0.24	0.17	0.22
MS420PJB124MSZ	120	3.50	7.70	11	0.20	0.22	0.23	0.15	0.20
MS420PJB154MSZ	150	4.25	6.30	9.0	0.18	0.20	0.21	0.14	0.18
MS420PJB224MSZ	220	6.25	4.90	7.0	0.15	0.16	0.17	0.12	0.16
MS420PJB334MSZ	330	8.60	3.85	5.5	0.12	0.13	0.14	0.10	0.15
MS420PJB474MSZ	470	12.7	3.15	4.5	0.090	0.11	0.11	0.090	0.12
MS420PJB564MSZ	560	15.7	2.80	4.0	0.090	0.10	0.10	0.080	0.11
MS420PJB684MSZ	680	20.0	2.59	3.7	0.090	0.097	0.10	0.070	0.10
MS420PJB105MSZ	1000	28.0	2.10	3.0	0.087	0.096	0.10	0.060	0.090

1. When ordering, please specify **screening** code:

MS420PJB335MSZ

Screening: Z = Unscreened

- H = Coilcraft CP-SA-10001 Group A
- G = Coilcraft CP-SA-10001 Group A (SLDC Option A)
- D = Coilcraft CP-SA-10001 Group A (SLDC Option B)
- 1 = EEE-INST-002 (Family 1) Level 1
- 2 = EEE-INST-002 (Family 1) Level 2
- 3 = EEE-INST-002 (Family 1) Level 3
- 4 = MIL-STD-981 (Family 04) Class B
- 5 = MIL-STD-981 (Family 04) Class S
- F = ESCC3201 (F4 operational life performed at 105°C)
- Screening performed to the document's latest revision.
- Lot qualification (Group B) available.
- Testing T and U have been replaced with more detailed codes 4, 5, and 1, 2, 3, respectively. Codes T and U can still be used, if necessary. Custom testing also available.
- Country of origin restrictions available; prefix options G or F.

2. Inductance tested at 100 kHz, 0.1 Vrms using an Agilent/HP 4192A.
 3. DCR measured on a micro-ohmmeter.
 4. SRF measured using an Agilent/HP 8753ES or equivalent.
 5. DC current at 25°C that causes the specified inductance drop from its value without current.
 6. Current that causes the specified temperature rise from 25°C ambient. This information is for reference only and does not represent absolute maximum ratings.
 7. Electrical specifications at 25°C.
- Refer to Doc 362 "Soldering Surface Mount Components" before soldering.

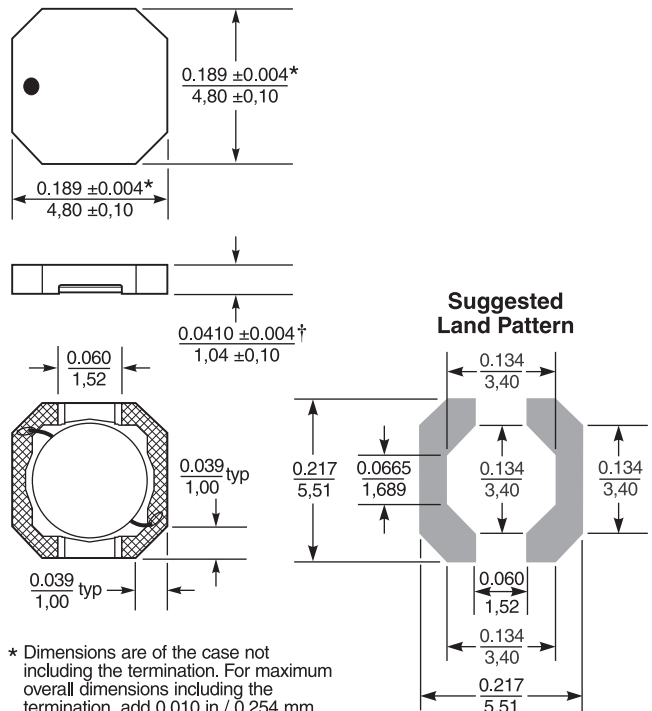

* Dimensions are of the case not including the termination. For maximum overall dimensions including the termination, add 0.010 in / 0,254 mm.

† Height dimension is after mounting. For maximum height dimension before mounting, add 0.006 in / 0,152 mm.

Dimensions are in $\frac{\text{inches}}{\text{mm}}$



1102 Silver Lake Road
Cary, IL 60013
Phone 800-981-0363

Fax 847-639-1508
Email cps@coilcraft.com
www.coilcraft-cps.com

Document MS536-2 Revised 09/30/22

This product may not be used in medical or high risk applications without prior Coilcraft approval. Specifications subject to change without notice. Please check our web site for latest information.